

## RS4 202 DIN Format SIL4 VITAL RELAY

### RS4 202 SIL4 Vital Relay

*RS4 System  
SIL4 Vital relay  
Safety contacts guaranteed to open  
2 NO 2 NC*



# RS4 202



## TECHNICAL FEATURES

- It integrates two PCB relays which meet NF F 50205 standard (forcibly guided relay).
- The two PCB relays are coming from different series to protect against the shared modes introduced by manufacturing errors involving a single series.
- Two "working" contacts from each PCB relay are twisted in series to work out the security output.
- The distances between the internal tracks and the pins of the safety control must respect the NF F 74003 standard to guarantee the absence of a short circuit
- The distances between the control of the PCB relays and the security output strips must resist to insulation tensions of 2000Vac.
- The circuit safety is processed with a SIL4 safety level
- RS4 relay is "fail safe", including design based on component failure according to EN50129 standard



■ **RS4 Dimensions : 90 x 90 x 22 mm**

## DESCRIPTION RS4 202

**Safety systems control is often done via safety relays. There is often confusion in the terms used for the notion of safety relay:**

### **RELAY FORCIBLY GUIDED ACCORDING TO EN 50205 STANDARD**

In reality a lot of safety relays are simply forcibly guided relays according to EN 50205 standard, guaranteeing that it is impossible that a NO (Normally Opened) contact and a NC (normally closed) contact are established at the same time.

### **RELAYS GUARANTEED TO BE FAIL-SAFE AND FORCIBLY GUIDED**

Relays like the NS1 relays which meet NF F 70-030 standard, are also guaranteed to be fail-safe (not all the NS1 relays, and the RU are not). The fail-safe guarantee is obtained by the fact that the moving part of the relay is orientated in relation to earth's attraction. This way, via the effect of gravity", the "working" contacts open if the relays coil is not powered. This implies that these relays may not be used in-board. These relays are mainly used in rail signaling facilities and are considered to be intrinsic safety relays with a SIL4 safety level.

The standards emphasize on the fact that these safety characteristics are only valid if the terms of use for these relays are respected (maximum supply tension at 28.8V, maximum current in the limited contacts, etc.).

### **Why has CLEARSY developed the RS4 RELAYS?**

We have developed and set up systems like COPPILOT, COPP, DOF1 and DIL which are intended to control the platform screen doors of various underground rail systems. The opening function on these systems is level SIL3. The opening control is achieved through existing relay contact in working position. The security of the safety function on CLEARSY's systems is based on the fact that we safely detect that the relay has remained "stuck" in the condition in which working contact is established. This principle was used to produce the RS2 relay: this relay is made up of 2 forcibly guided relays and allows, thanks to an external check of the contacts (by a security automaton for example) to guarantee a SIL3 safety level.

For security applications which have no checking system, we have designed an automatically checked relay named RS4. The RS4 is functionally comparable to the NS1 because the RS4 relay is an intrinsic safety relay with a SIL4 safety level. The RS4 is "forcibly guided " AND " fail-safe ", including design based on component failure according to EN50129 standard. Like the NS1 relay, certain conditions of use must be respected to guarantee the SIL4 safety integrity

# RS4 202

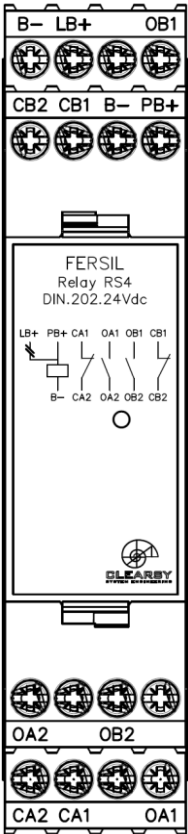

TERMINAL ASSIGNMENT	
Pin	Description
LB+ B-	Line command (input between 18 Ω and 45 Ω)
PB+ B-	Poste command (input < 18 Ω)
OA1 OA2	NO A Contact
OB1 OB2	NO B Contact
CA1 CA2	NC A Contact (type 2)
CB1 CB2	NC B Contact (type 1)

Only one input can be use at the same time (LB+ or PB+).  
 NO means a normally open contact (or working contact).  
 NC means a normally closed contact (or break contact).

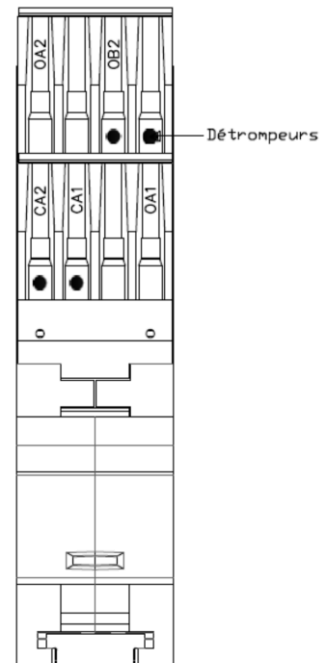
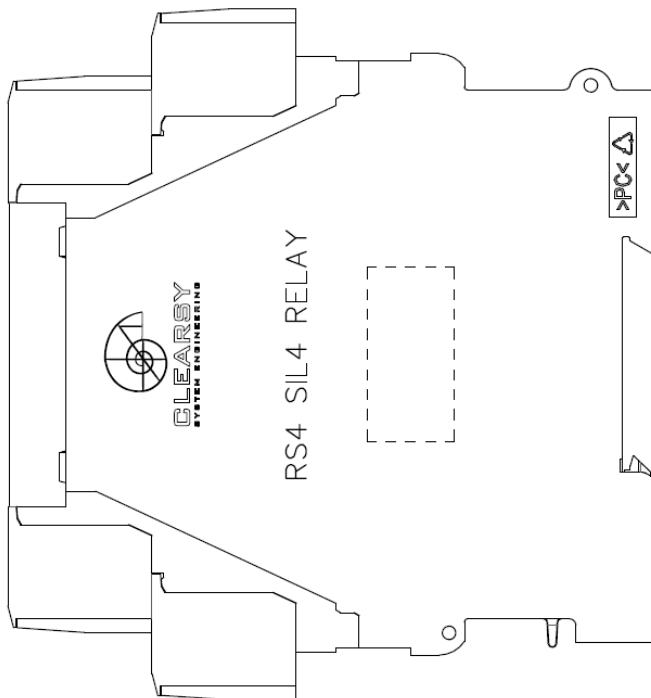
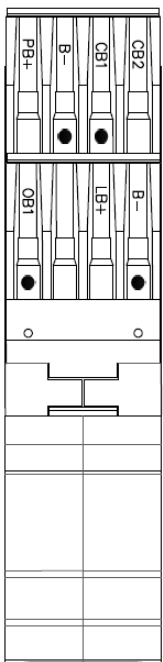
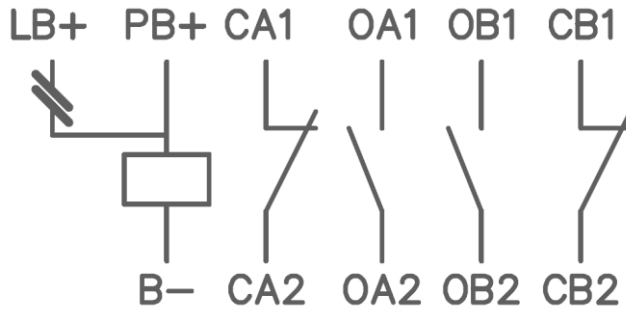

# RS4 202

RELAY TYPE		RS4-202
<b>1 Command coil data</b>		
1.1 Nominal Voltage	VDC	24, 48, 72, 110 (other on demand)
1.2 Nominal power	W	1,7
1.3 Operating voltage range	V	22,56 ... 28,8 VDC
1.4 Drop out specified (in % of Un)	Un	More than 0,1*Un mean: >2 VDC
1.5 Command signal maximum rise time	ms	The command signal must rise from 0 to the nominal voltage in less than 30ms.
1.6 Relay minimum command current	A	At least 0.8A
1.7 Maximum number of switching per second should not be exceeded	switching / secondes	1
1.8 Power input maximum equivalent series resistance. (this value should be used to calculate the maximum conductor length in function of the wire type $\Omega$ /meter value)	$\Omega$	$\leq 18\Omega$ on " poste" input $18\Omega < R \leq 45\Omega$ on " line" input
<b>2 Contacts</b>		
2.1 Contacts configuration		2NO / 2NF Forcibly guided contacts in accordance with EN50205 standard.
2.2 Contact material		AgNi 0,15 + 5um Au
2.3 Dielectric strength between coils and contacts and between contacts	VAC	2000 (1 minute)
Maximum contact breaking nominal voltage	V	230 VAC and 230 VDC
Minimum contact making voltage	V	1 VAC and 230 VDC
2.4 Minimum making current	mA	4mA DC 4mA AC
2.5 Maximum nominal load current	A	3A DC /AC
2.6 Minimum power making.	mW	4 mW
2.7 Maximum AC power breaking	VA	460
2.8 Electrical life expectancy 230Vac 3A cos $\phi = 1$ 24Vdc 3A 230Vac 0.3A cos $\phi = 1$ 24Vdc 0.3A	Number of cycles	Greater than $2.2 \cdot 10^5$ Greater than $1.5 \cdot 10^5$ Greater than $3 \cdot 10^6$ Greater than $1 \cdot 10^6$
2.9 Pick-up closure time contact Ta for NO contacts	ms	<b>5 &lt; Ta &lt; 120 ms</b> Typical at 24Vdc : 35ms
2.10 Drop-out opening contact time T'c for NO contacts	ms	<b>5 &lt; T'c &lt; 50ms</b> Typical at 24Vdc : 28ms
2.11 Pick-up closure time contact Ta for NC contacts	ms	<b>1 &lt; ta &lt; 60 ms</b> Typical at 24Vdc NF1: 20 ms Typical at 24Vdc NF2: 4 ms
2.12 Drop-out opening contact time tc for NC contacts	ms	<b>1 &lt; tc &lt; 40 ms</b> Typical at 24Vdc NF1: 7 ms Typical at 24Vdc NF2: 7ms
2.13 Contact bouncing	ms	20
<b>3 Other</b>		
3.1 Mechanical life	Number of operations	Supérieur à $20 \cdot 10^6$
3.2 MTTR	hour	0,08
3.3 Operating temperature range	°C	-25 ... +70°C (EN 50155 Class T1)
3.4 Choc and Vibration		Compliant with EN 61373 Category 1 Class B
3.5 Supply interruption		EN 50155 Class S1 (without interruption)
3.6 Supply change over		Class C1 at 0.6 Un during 100ms (without interruptions)

# CLEARSY

Safety Solutions Designer

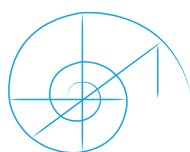

320 AVENUE ARCHIMEDE - LES PLEIADES III BAT A  
13100 AIX-EN-PROVENCE - FRANCE

Tél. +33 (0)4 42 37 12 70 - Fax : +33 (0)4 42 37 12 71

[contact@clearsy.com](mailto:contact@clearsy.com) | [www.clearsy.com](http://www.clearsy.com)

[www.fersil-railway.com](http://www.fersil-railway.com)