

## RS4 2X202 3U SIL4 VITAL RELAY

---

### RS4 2X202 3U SIL 4 Vital Relay

---

*RS4 System  
SIL4 Vital relay  
Safety contacts guaranteed to open  
2 NO 2 NC*



# RS4 2X202 3U



## TECHNICAL FEATURES:

- It integrates two PCB relays which meet DIN EN 61810-3 standard (forcibly guided relay).
- The two PCB relays are coming from different series to protect against the shared modes introduced by manufacturing errors involving a single series.
- Two "working" contacts from each PCB relay are twisted in series to work out the security output.
- The distances between the internal tracks and the pins of the safety control must respect the NF F 74003 standard to guarantee the absence of a short circuit
- The distances between the control of the PCB relays and the security output strips must resist to insulation tensions of 2000Vac.
- The circuit safety is processed with a SIL4 safety level
- RS4 vital relay is "fail safe", including design based on component failure according to EN50129 standard



■ **RS4 Dimensions : 172 x 130 x 20 mm**

## DESCRIPTION RS4 2X202 3U

[Safety systems control is often done via safety relays. There is often confusion in the terms used for the notion of safety relay:](#)

### RELAY FORCIBLY GUIDED ACCORDING TO EN 61810-3 STANDARD

In reality a lot of safety relays are simply forcibly guided relays according to EN 61810-3 standard, guaranteeing that it is impossible that a NO (Normally Opened) contact and a NC (normally closed) contact are established at the same time.

### RELAYS GUARANTEED TO BE FAIL-SAFE AND FORCIBLY GUIDED

Relays like the NS1 relays which meet NF F 70 030 standard, are also guaranteed to be fail-safe (it is also the same analysis for Q-relay). The fail-safe guarantee is obtained by the fact that the moving part of the relay is orientated in relation to earth's attraction. This way, via the effect of gravity", the "working" contacts open if the relays coil is not powered. This implies that these relays may not be used in-board. These relays are mainly used in rail signaling facilities and are considered to be intrinsic safety relays with a SIL4 safety level.

The standards emphasize on the fact that these safety characteristics are only valid if the terms of use for these relays are respected (maximum supply tension at 28.8V, maximum current in the limited contacts, etc.).

### [Why has CLEARSY developed the RS4 RELAYS?](#)

We have developed and set up systems like COPPILOT, COPP, DOF1 and DIL which are intended to control the platform screen doors of various underground rail systems. The vital function on these systems is SIL3. The opening control is achieved through existing relay contact in working position. The security of the safety function on CLEARSY's systems is based on the fact that we safely detect that the relay has remained "stuck" in the condition in which working contact is established. This principle was used to produce the RS2 relay: this relay is made up of 2 forcibly guided relays and allows, thanks to an external check of the contacts (by a security automaton for example) to guarantee a SIL3 safety level.

For security applications which have no checking system, we have designed an automatically checked relay named RS4. The RS4 is functionally comparable to the traditional vital relays because the RS4 relay is an intrinsic safety relay with a SIL4 safety level. The RS4 is "forcibly guided " AND " fail-safe ", including design based on component failure according to EN50129 standard. Like the NS1 relay, certain conditions of use must be respected to guarantee the SIL4 safety integrity

# RS4 2X202 3U

TERMINAL ASSIGNMENT		
Relay	Pin	Description
1	E30	Line command (input between 27 Ω and 45 Ω)
1	E32	Poste command (input < 18 Ω)
1	C28 / A28	NO Contact A
1	C24 / A24	NO Contact B
1	E26 / E22	NF Contact A (type 1)
1	C14 / A14	NF Contact B (type 2)
2	A2	Line command (input between 18 Ω and 45 Ω)
2	E2	Poste command (input < 18 Ω)
2	C6 / A6	NO Contact A
2	C10 / A10	NO Contact B
2	E8 / C12	NF Contact A (type 1)
2	C14 / A14	NF Contact B (type 2)

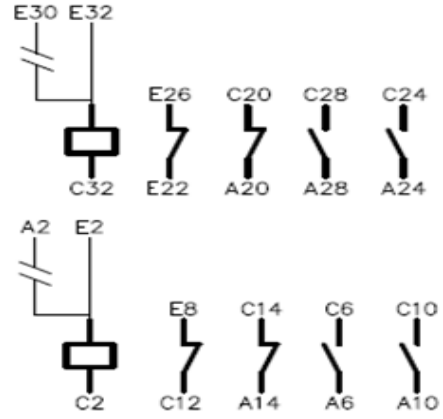

Contact NO mean normally opened (or working contact).  
 Contact NC mean Normally Closed (or release contact).

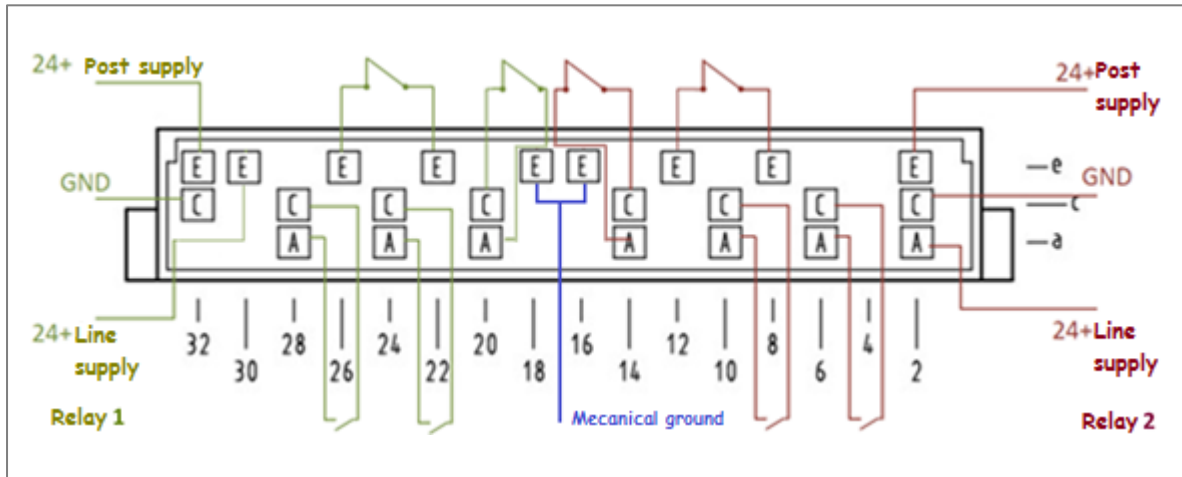

- Above, the position on the connector E48 of the useful contacts of the model RS4 3U doubles relay **RS4-3U-2X202-24V**. There is also a model format 3U simple relay **RS4-3U-202-24V**, in this case only the relay 1 is present.

# RS4 2X202 3U

RELAY TYPES		RS4-3U-2X202 or RS4-3U-202
<b>1 Command coil data</b>		
1.1 Nominal Voltage	VDC	24
1.2 Nominal power	W	1,7 @24Vdc
1.3 Operating voltage range	V	22,56 ... 28,8 Vdc @24Vdc
1.4 Drop out specified (in % of Un)	Un	More than 0,1*Un mean: >2 VDC
1.5 Command signal maximum rise time	ms	The command signal must rise from 0 to the nominal voltage in less than 30ms.
1.6 Relay maximum inrush current	A	0.8 A @24Vdc
1.7 Maximum number of switching per second should not be exceeded	switching / secondes	1
1.8 Power input maximum equivalent series resistance. (this value should be used to calculate the maximum conductor length in function of the wire type $\Omega$ /meter value)	$\Omega$	<b>En 24Vdc :</b> $\leq 18\Omega$ on « Poste » input (PB+) $27\Omega < R \leq 45\Omega$ on « Line » input (LB+)
<b>2 Contacts</b>		
2.1 Contacts configuration		2NO / 2NF Forcibly guided contacts in accordance with EN61810-3 standard.
2.2 Contact material		AgNi 0,15 + 5um Au
2.3 Dielectric strength between coils and contacts and between contacts	VAC	2000 (1 minute)
Maximum contact breaking nominal voltage	V	1 VAC and 1 VDC
Minimum contact making voltage	V	230 VAC and 230 VDC Breaking a load with an operating voltage greater than 60VDC will volatilize the 5um contact gold plating. In this case the minimum voltage to apply increases from 1V to 10 VDC.
2.4 Minimum making current	mA	4mA DC 4mA AC
2.5 Maximum nominal load current	A	3A DC /AC Breaking a load carrying a current greater than 0.3A DC or AC will volatilize the 5um contact gold plating. In this case the minimum current to apply must be at least 20 mA DC or AC.
2.6 Minimum power making.	mW	4 mW
2.7 Maximum AC power breaking	VA	460 Breaking a load carrying a power greater than 7W will volatilize the 5um contact gold plating. In this case the minimal power to apply increases from 4mW to 200mW
2.8 Electrical life expectancy 230Vac 3A cos $\phi = 1$ 24Vdc 3A 230Vac 0.3A cos $\phi = 1$ 24Vdc 0.3A	Number of cycles	Greater than $2.2 \cdot 10^5$ Greater than $1.5 \cdot 10^5$ Greater than $3 \cdot 10^6$ Greater than $1 \cdot 10^6$
2.9 Pick-up closure time contact Ta for NO contacts	ms	<b>5 &lt; Ta &lt; 120 ms</b> Typical at 24Vdc : 35ms Typical at 110 VDC : 55ms
2.10 Drop-out opening contact time T'c for NO contacts	ms	<b>5 &lt; T'c &lt; 50ms</b> Typical at 24Vdc : 28ms Typical at 110 VDC : 37ms
2.11 Pick-up closure time contact Ta for NC contacts	ms	<b>1 &lt; ta &lt; 60 ms</b> Typical at 24Vdc NF1: 20 ms Typical at 24Vdc NF2: 4 ms
2.12 Drop-out opening contact time tc for NC contacts	ms	<b>1 &lt; tc &lt; 40 ms</b> Typical at 24Vdc NF1: 7 ms Typical at 24Vdc NF2: 7ms
2.13 Contact bouncing	ms	20

# RS4 2X202 3U

## 3 Other

3 Other		
3.1 Mechanical life	Number of operations	>s 20*10^6
3.2 MTTR	hour	0,08
3.3 Operating temperature range	°C	-40 ... +70°C (EN 50155 Class T1)
3.4 Choc and Vibration		Compliant with EN 61373 Category 1 Class B
3.5 Supply interruption		EN 50155 Class S1 (without interruption)
3.6 Supply change over		Class C1 at 0.6 Un during 100ms (without interruptions)

# CLEARSY

Safety Solutions Designer

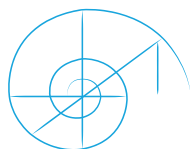

320 AVENUE ARCHIMEDE - LES PLEIADES III BAT A  
13100 AIX-EN-PROVENCE - FRANCE

Tél. +33 (0)4 42 37 12 70 - Fax : +33 (0)4 42 37 12 71  
[contact@clearsy.com](mailto:contact@clearsy.com) | [www.clearsy.com](http://www.clearsy.com)